



ARUVO™ AXEL Composite Stone Wall-hung Basin

SKU: CSB-WH-AXEL G02 900

| | |
|---------------------|-----------------|
| Material | Composite Stone |
| Installation | Wall-mount |
| Width | 900mm |
| Depth | 400mm |
| Height | 200mm |
| Waste Size | 50mm |
| Overflow | No |
| Colour | White |
| Finish | Matte |
| Pre-drilled Taphole | No |

Reommend to pair with ARUVO Evolve Bottle Trap which is Sold Separately. Available in Chrome / Brushed Nickel / Gunmetal / Matte Black.

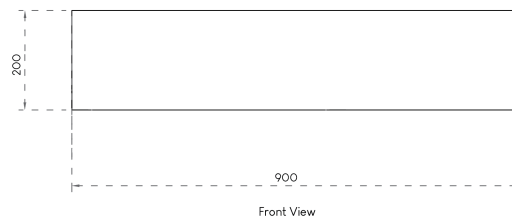
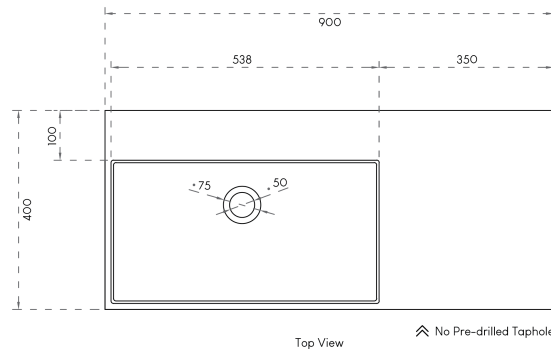

Luxurious, Smooth and Velvety to Touch



Highly Durable



Stain, Mold and Bacteria Resistant



7 Year Warranty

