

**SPECIFICATION SHEET**

**ARUVO™ SKYLAR 1700 Freestanding Bath**

SKU: BTH-ARCS-CS8863 SKYLAR1700



|                     |                 |
|---------------------|-----------------|
| <b>Material</b>     | Composite Stone |
| <b>Installation</b> | Freestanding    |
| <b>Width</b>        | 1700mm          |
| <b>Depth</b>        | 800mm           |
| <b>Height</b>       | 520mm           |
| <b>Weight</b>       | 131KG           |
| <b>Waste Size</b>   | 40mm            |
| <b>Overflow</b>     | No              |
| <b>Colour</b>       | White           |
| <b>Finish</b>       | Matte           |

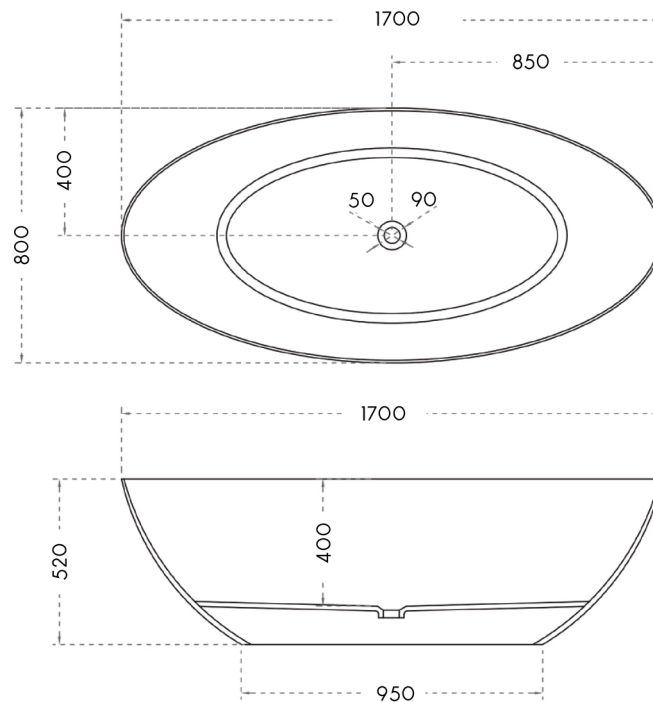

Luxurious, Smooth and Velvety to Touch



Stain, Mould and Bacteria Resistant



Highly Durable



7 Year Warranty

